



We Build the Invisible



We Build the Invisible

CLASSIC DECOR CONSTRUCT VARIANCE P
SABCO OSF ROMEO SWIMSIDE



**GARDE CORPS
NEZ DE DALLE**
000110

© Document émis par la société Sadev - Reproduction, modification et communication interdites sans autorisation. Crédits photos © Sadev - DOCBRO-ROMEO-FR-260922

Membre du
**GRUPE
SIMONSWERK**

Tél. +33(0) 4 50 08 39 00 | info@sadev.com
76, chemin des Poses - 74330 Poisy (France)

sadev.com
suivez-nous sur



Membre du
**GRUPE
SIMONSWERK**

CONNAISSEZ-VOUS
TOUS LES AVANTAGES
de nos 000110 ?



3

SYSTÈMES DE RÉGLAGE
POUR UN MONTAGE
ULTRA FACILE

1^{er} RÉGLAGE

Positionner le point de fixation

Réglage horizontal : de + ou - 10 mm

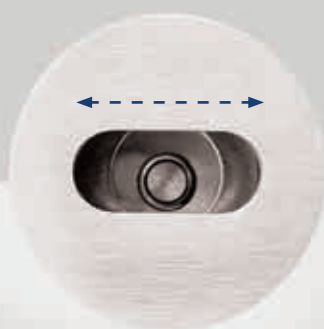

2^{ème} RÉGLAGE

Régler l'aplomb du verre

Ajustement de la profondeur :
de + ou - 5 mm



3^{ème} RÉGLAGE

Fixer le verre du premier coup

Ajustement multidirectionnel (excentrique)
de + ou - 5 mm

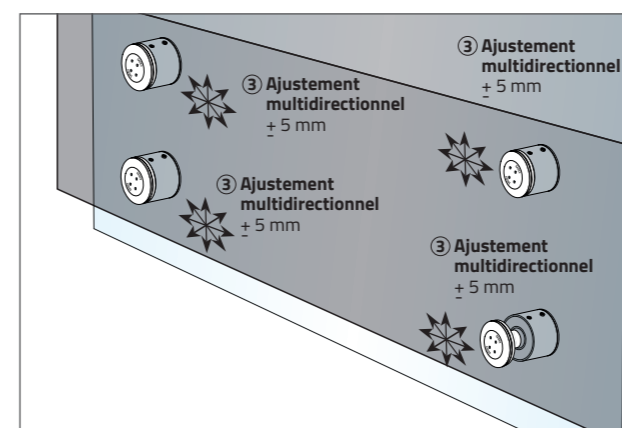
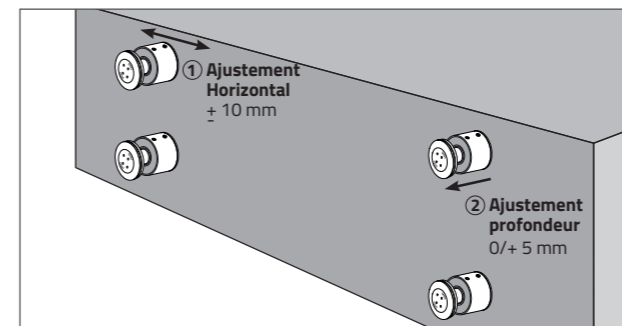
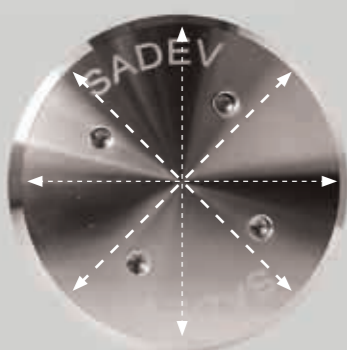

POINTS NEZ DE DALLE

Réf. **000110** (Inox 304)

Réf. **000110A4** (Inox 316)

CARACTÉRISTIQUES TECHNIQUES



250

SPÉCIFICITÉ	Double système d'ajustement du verre
Diamètre	50 mm
Hauteur	40 mm à 45 mm
Poids	465 gr
Matière	Inox 304 & 316
Serrage vis du verre	Monolithique trempé = Mini 15 N.m Feuilleté trempé
Type de verre	Verre Feuilleté - trempé type 8 / 8, 10 / 10, 12 / 12 ou 15 / 15 suivant configuration
Visserie	Vis à tête cylindrique Fixation au support Ø12 mm. Cheville à définir en fonction de la nature de la dalle ou du support. Hors fourniture SADEV
Vis pour le verre	Cylindrique Ø50
Dimensions de verre validées	Hauteur 1 260 mm Longueur 1 000 à 1 400 mm
Épaisseur du verre	17,52 mm 21,52 mm 25,52 mm 31,52 mm

CERTIFICATIONS

Rapport d'essai N°BEB1.9.4027-9
Rapport d'essai N°BEB1.9.4027-15
Rapport d'essai N°BEB1.9.4027-16

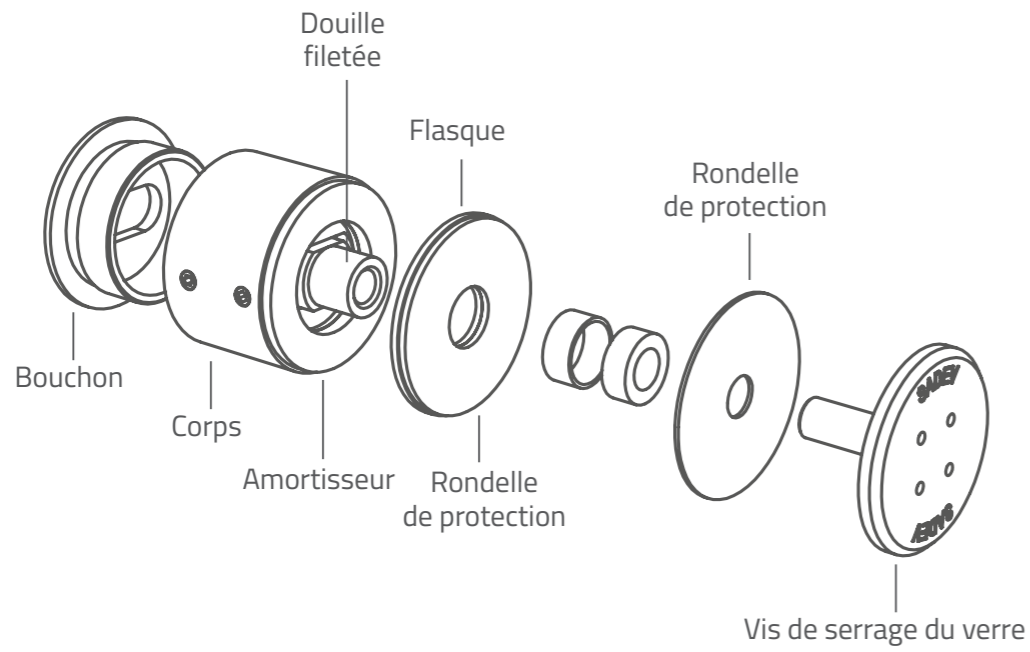

PLANS TECHNIQUES

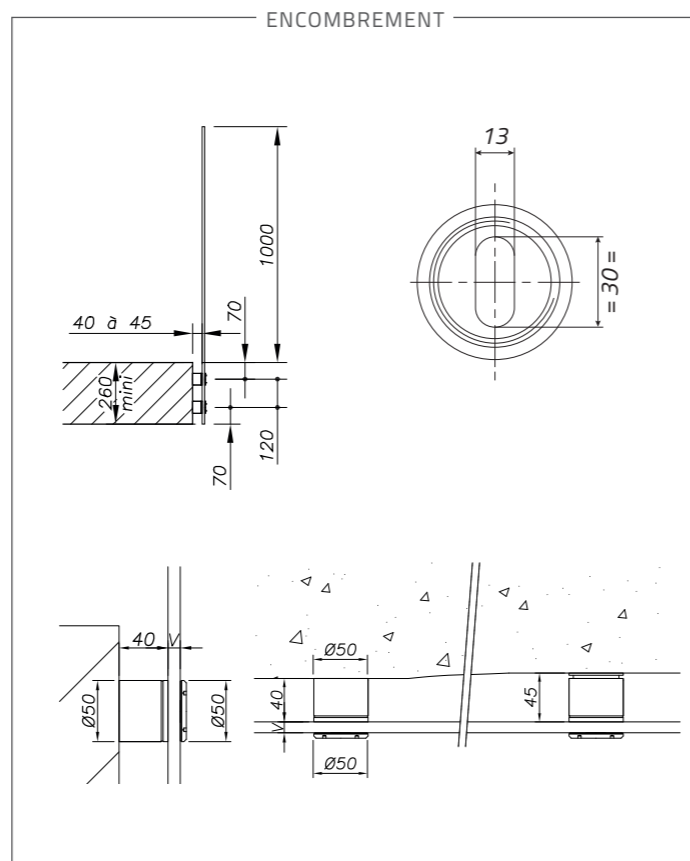
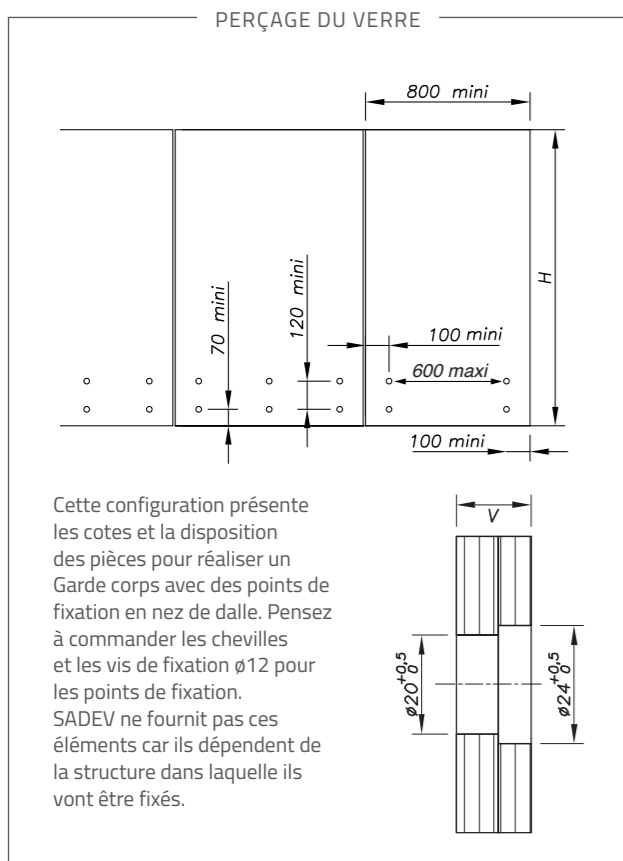

UNE FINITION ESTHÉTIQUE ET MODERNE

Pour usage intérieur : Inox 304

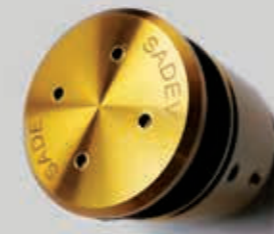

Doré
Réf. 000110OR



Champagne
Réf. 000110CH



Cuivré
Réf. 000110CU



Inox brossé
Réf. 000110



Doré brossé
Réf. 000110OR-B



Champagne brossé
Réf. 000110CH-B



Cuivré brossé
Réf. 000110CU-B



Noir
Réf. 000110N





POINTS NEZ DE DALLE - Hauteur 30 mm
Réf. **000130**



Finition noir

CARACTÉRISTIQUES TECHNIQUES

SPÉCIFICITÉ Réglage + ou - 10 mm

Diamètre	Hauteur	Référence	Matière	Épaisseur du verre
50 mm	30 mm	000130	Inox 304	17.52 > 21.52 mm
		000130-25	Inox 304	22 > 25.52 mm
		000130N	Inox 304 Finition noir	17.52 > 21.52 mm
		000130A4	Inox316	17.52 > 21.52 mm

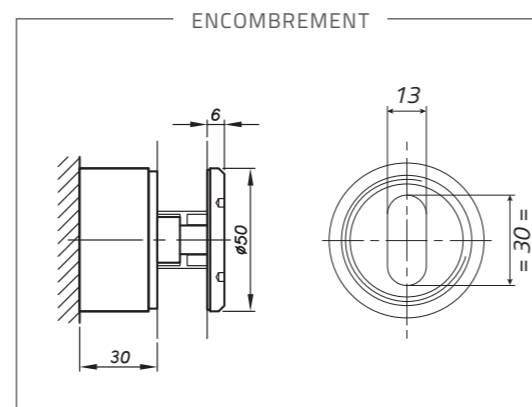
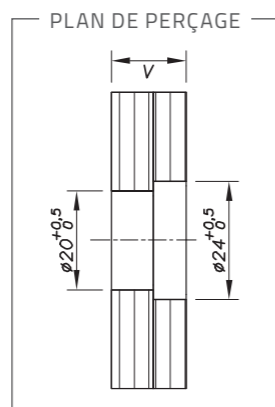

POINTS NEZ DE DALLE - Hauteur 20 mm
Réf. **000120**



Finition noir

CARACTÉRISTIQUES TECHNIQUES

SPÉCIFICITÉ Réglage + ou - 10 mm

Diamètre	Hauteur	Référence	Matière	Épaisseur du verre
50 mm	20 mm	000120	Inox 304	17.52 > 21.52 mm
		000120-25	Inox 304	22 > 25.52 mm
		000120N	Inox 304 Finition noir	17.52 > 21.52 mm
		000120A4	Inox316	17.52 > 21.52 mm

